

BAB-501 Iontophoresis Pump

High Voltage Constant Current Source for MicroAmpere Microiontophoresis

General description

The BAB-501 iontophoresis pump is specifically designed for extracellular iontophoretic deposition of neural dyes and transport tracer substances such as Pontamine Sky Blue, Horseradish peroxidase (HRP) or *Phaseolus vulgaris* leucoagglutinin. Its maximum output current is 20 μA set by a ten-turn dial. The maximum compliance voltage can be switched to either 500 V or 200 V. The latter one is used when current is passed through the headstage of an extracellular amplifier like our ExAmp-20Ks. Three modes of operation can be selected. In continuous mode, iontophoresis current is continuously generated when the polarity switch is in "Positive" or "Negative" position. In "External" mode, the BAB-501 can be gated through its "External" BNC jack by timers, logic pulse generators or computers. The output current is on whenever the gating input is logic high, off when it is logic low. In pulse mode, an internal timer turns on the output current for 7 s every 14 s generating 7s on/ 7s off cycles. Polarity of the output current is switch selected. A built-in 10 M Ω resistor can be selected for termination to preview the required current. The current sensing resistor is in series with the current source providing a true measurement of the output current. The unit's high voltage circuitry is galvanically isolated from the input DC power providing a floating current output which is not referenced to the line ground.

Front panel controls

- Power:** This LED-tipped switch turns unit on or off.
- Compliance:** Selects the maximum compliance voltage range. Use 200V when currents are to be passed through the headstage of an extracellular amplifier or similar device. Check specifications of the other device.
- Mode:** In "Continuous" mode, iontophoresis current is continuously generated. In "External" mode, the unit can be gated through its "External" BNC jack by any logic pulse generator or computer. In "Pulse" mode, an internal timer turns on the output current for 7s every 14s generating 7s on/7s off cycles.
- Polarity:** Polarity of the "Electrode" output in reference to the "Ground" output can be selected by this switch.
- Liquid Crystal Display (LCD):** Displays current that actually flows through the iontophoresis pipette or the internal 10 M Ω dummy load. Sampling (refresh) rate of the display is 2.5 Hz.
- Load:** Select either "Electrode" to deliver iontophoresis currents or "Internal 10 M Ω " dummy load to preview the required current.
- Current:** Output current can be adjusted by this ten-turn knob up to 20 μA .
- Ground:** The ground or returning path electrode should be connected this output.
- Electrode:** This output delivers the iontophoresis current with the selected polarity in reference to the "Ground" output.

Front panel view

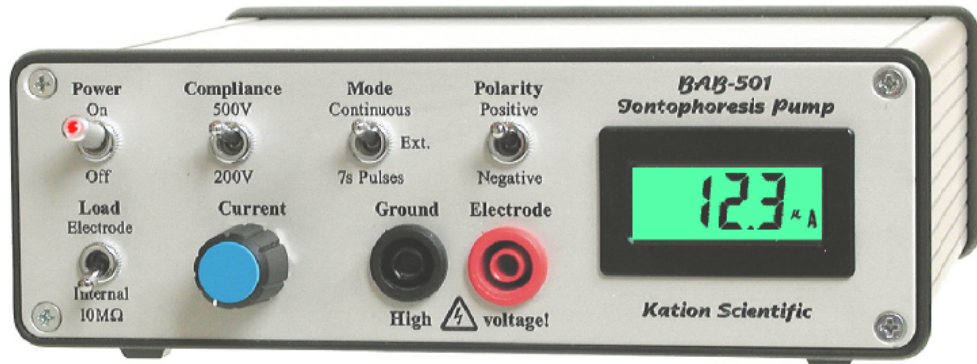

Color of parts may vary

Specifications

Output current:	$\pm 20 \mu\text{A}$, maximum
Compliance voltage:	$\pm 500 \text{ V}$ or ± 200 , switch selectable
Polarity:	+/-, switch selected
Termination:	Electrode/10 M Ω internal dummy load
Load configuration:	Floating
Mode of operation:	Continuous/External/Pulsed
Pulse duration:	7 seconds, factory set
External control:	Through 'External' BNC jack using TTL or CMOS gating signals
Power supply:	External 12V DC, 100mA
Duty cycle:	50% (7s on/7s off)
Case material:	Aluminum
Dimensions (WxHxD):	6.67" x 2.19" x 6.45" (169.5 x 55.6 x 164.0 mm)
Weight:	1.7 lbs (770 grams)

Basic principle of microiontophoresis

If a voltage is applied to a solution, ions and charged molecules will migrate toward and away from the source of the imposed electrical field depending upon the sign of their net charge.

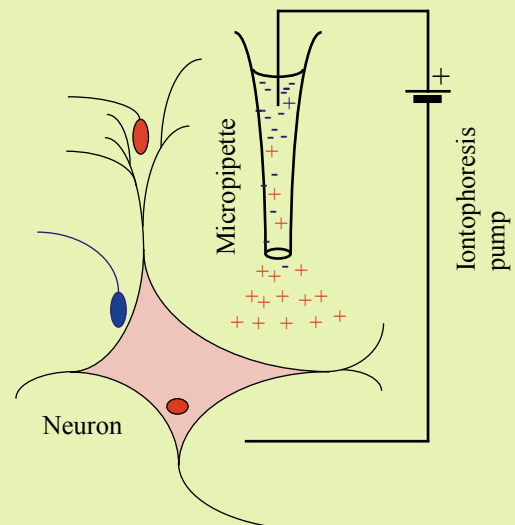

The direction of current flow necessary to eject cations.

Kation Scientific, P.O. Box 14674, Minneapolis, MN 55414 Phone/Fax: (651) 698-5167.

E-mail: info@kationscientific.com Web site: <http://www.kationscientific.com>

Performing an experiment

Turn the unit on in continuous mode using the 10 M Ω internal dummy load for termination. Allow a few minutes for thermal equilibration. Connect the factory provided banana plugs to mini grabbers cable to the "Ground" and "Electrode" outputs with Ground to GND polarity. The red grabber will deliver the iontophoresis current into the micropipette through a piece of platinum or silver wire. The polarity of the current flowing through the red grabber is selected by the "Polarity" switch and is referenced to the "Ground" output *i.e.* to the black grabber. To provide a path for the returning current, ground the black grabber to the experimental system (*e.g.* by grabbing the skin of the experimental animal).

Using the current adjusting knob, select the required current level. Select "Electrode" for termination and use the "Mode" switch if other than continuous mode of operation is needed. The unit is now ready to deliver the pre-selected current: turn "Polarity" switch into either positive or negative position and iontophoresis will immediately take place at the tip of the micropipette in continuous mode. The iontophoresis current can be gated externally via the "External" BNC connector or it can be pulsed by an internal timer when selected by the "Mode" selector switch. In the latter case, current will be delivered in 7s on, 7s off cycles.

Useful tips: Keep in mind that microiontophoresis involves two-way traffic of electrically charged particles. Imposing an electrical field on your micropipette will cause the compound of interest to be ejected, but at the same time, oppositely charged particles, including tissue debris, will enter the pipette and may cause blockage. When the pipette gets clogged with tissue particles during iontophoresis the current may decline correspondingly. It is often helpful to reverse the polarity for 10 to 30 sec in such cases. If this does not help then increase the diameter of the pipette's tip. Tissue debris particles are negatively charged so ejecting micropipettes always tend to get clogged faster when cations are ejected with positive currents. For this reason, opt for working with anions if you have the freedom to do so. Do not use too high ejection currents! In many cases, less current produces better results. Too high currents speed up pipette clogging and/or may cause hydrolysis (bubbles) which, in turn, destroys the iontophoresis process.

For a list of iontophoretically applied neural dyes and tract-tracing materials or application examples visit our web site. See URL below.

Rear panel view

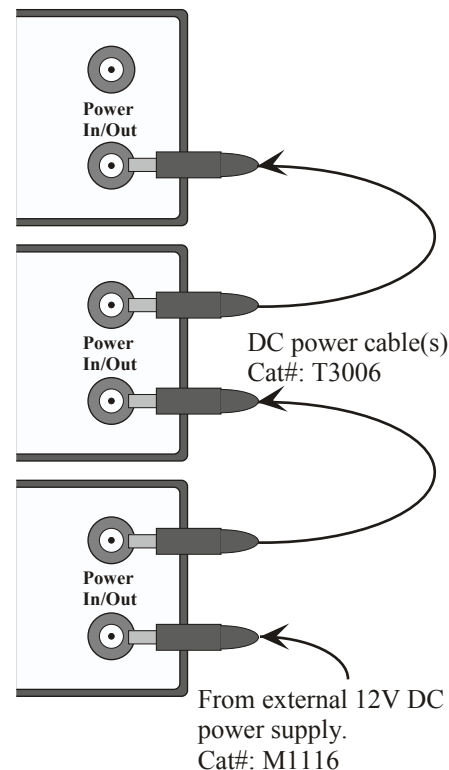
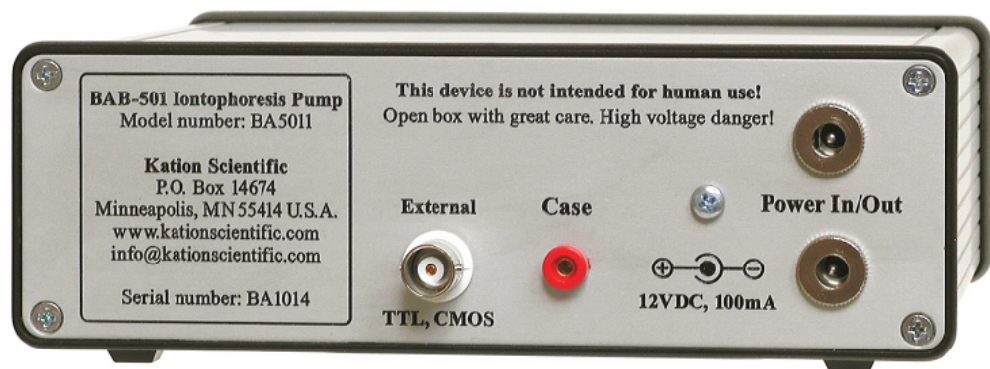

Power In/Out: Two identical DC power jacks. Type: 2.1 mm x 5 mm.

Case: The aluminum case of the unit can be connected through this miniature banana jack to the system ground if necessary.

External: Input for the external gating signal to turn the unit on/off when the "External" mode of operation is selected. Use TTL or CMOS (+5V) signals.
Switching time: 0.5 msec; switching current: 3 mA.

Power supply

The international power supply that Kation Scientific offers (Cat#: M1116) can provide power for several of our instruments provided that the combined power consumption is under 830 mA. Use a chain formation when multiple units are to be supplied from one source, as shown on the right. The employed power supply is double isolated for safety. Current output of the BAB-501 is isolated from the line power ground.

Daisy chaining multiple units

Certification:

Kation Scientific certifies that this instrument has been tested and inspected thoroughly and was found to meet all published specifications before shipment from the factory.

Warranty:

This product is warranted against defects in materials and workmanship for one full year from the date of shipment as long as it has been exposed to normal and proper use. Products which prove to be defective during the warranty period will be repaired or replaced without charge provided they are returned to the factory. Kation Scientific will provide for servicing and calibration after the warranty period for a reasonable service charge. The instrument should be shipped to the factory postage prepaid.

Kation Scientific, P.O. Box 14674, Minneapolis, MN 55414 Phone/Fax: (651) 698-5167.

E-mail: info@kationscientific.com Web site: http://www.kationscientific.com